

ELECTRONIC KEYBOARD

Owner's Manual

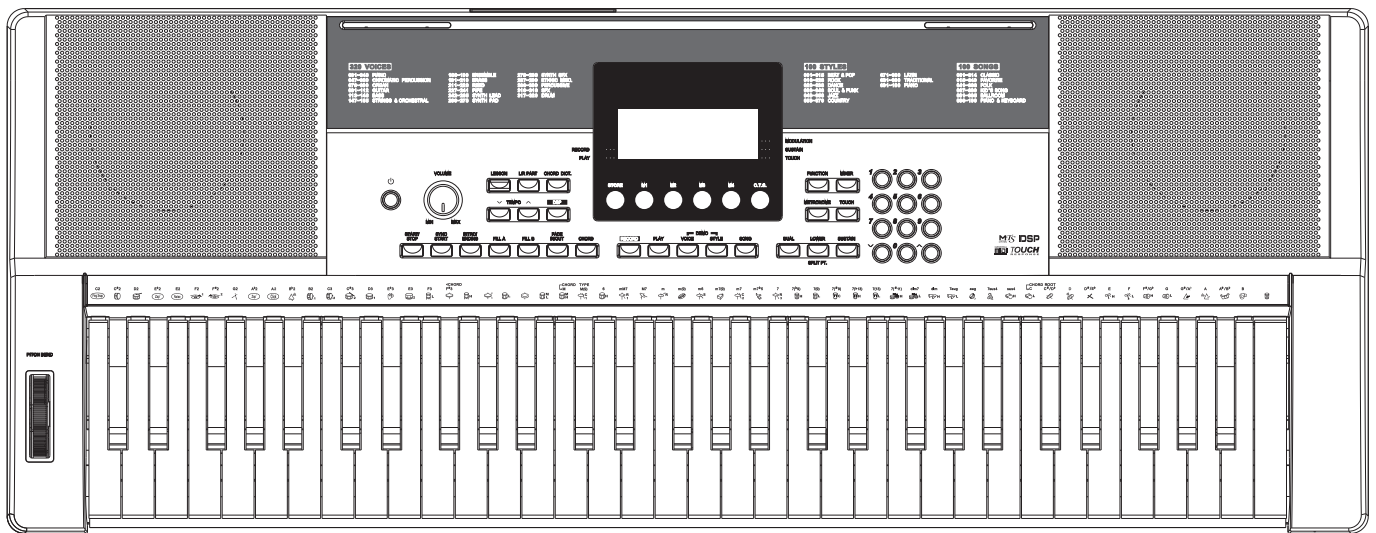

THE FCC REGULATION WARNING (for USA)

This equipment has been tested and found to comply with the limits for a Class B digital device, pursuant to Part 15 of the FCC Rules.

These limits are designed to provide reasonable protection against harmful interference in a residential installation. This equipment generates, uses, and can radiate radio frequency energy and, if not installed and used in accordance with the instructions, may cause harmful interference to radio communications. However, there is no guarantee that interference will not occur in a particular installation. If this equipment does cause harmful interference to radio or television reception, which can be determined by turning the equipment off and on, the user is encouraged to try to correct the interference by one or more of the following measures:

- Reorient or relocate the receiving antenna.
- Increase the separation between the equipment and receiver.
- Connect the equipment into an outlet on a circuit different from that to which the receiver is connected.
- Consult the dealer or an experienced radio/TV technician for help.

Unauthorized changes or modification to this system can void the user's authority to operate this equipment.

CAUTION

The normal function of the product may be disturbed by Strong Electro Magnetic Interference. If so, simply reset the product to resume normal operation by following the owner's manual. In case the function could not resume, please use the product in other location.

PRECAUTIONS

PLEASE READ CAREFULLY BEFORE PROCEEDING

Please keep this manual in a safe place for future reference.

Power Supply

Please connect the designated AC adaptor to an AC outlet of the correct voltage.

Do not connect it to an AC outlet of voltage other than that for which your instrument is intended.

Unplug the AC power adaptor when not using the instrument, or during electrical storms.

Connections

Before connecting the instrument to other devices, turn off the power to all units. This will help prevent malfunction and / or damage to other devices.

Location

Do not expose the instrument to the following conditions to avoid deformation, discoloration, or more serious damage:

- Direct sunlight
- Extreme temperature or humidity
- Excessive dusty or dirty location
- Strong vibrations or shocks
- Close to magnetic fields

Interference with other electrical devices

Radios and televisions placed nearby may experience reception interference. Operate this unit at a suitable distance from radios and televisions.

Cleaning

Clean only with a soft, dry cloth. Do not use paint thinners, solvents, cleaning fluids, or chemical-impregnated wiping cloths.

Handling

Do not apply excessive force to the switches or controls.

Do not let paper, metallic, or other objects into the instrument. If this happens, unplug the AC adaptor from the wall outlet. Then have the instrument inspected by qualified service personnel.

Disconnect all cables before moving the instrument.

Panel & Display Description		Other Function	
Front Panel.....	4	Function Menu.....	13
Rear Panel.....	4	Mixer.....	14
Display.....	5		
Setup		Memory	
Power Supply.....	6	Memory.....	15
Connections		Chord Dictionary.....	15
Connecting a Footswitch.....	7	Playing the Songs	
Connecting a pair of Headphones.....	7	Listening to the Songs.....	16
Connecting an Audio Equipment.....	7	Lesson Mode.....	16
Connecting a Computer.....	7	Recording and Playback.....	17
Playing the Demos.....	8	MIDI Functions	
Playing the Voices		What's MIDI?.....	18
Selecting a Voice.....	8	MIDI Terminals.....	18
Playing Two Voice Simultaneously-DUAL.....	8	Trouble Shooting.....	19
Lower.....	9	Specifications.....	19
Touch.....	9	Appendices	
Sustain.....	9	Voice List.....	20
Pitch Bend Wheel.....	9	Style List.....	22
DSP Effect.....	9	Song List.....	23
Playing the Styles		MIDI Implementation Chart.....	24
Selecting a style.....	10		
Playing a Fill.....	10		
Intro/Ending.....	10		
Sync Start.....	11		
Fade In/Out.....	11		
Tempo.....	11		
One Touch Setting.....	11		
Auto Bass Chord.....	12		

Panel & Display Description

Front Panel

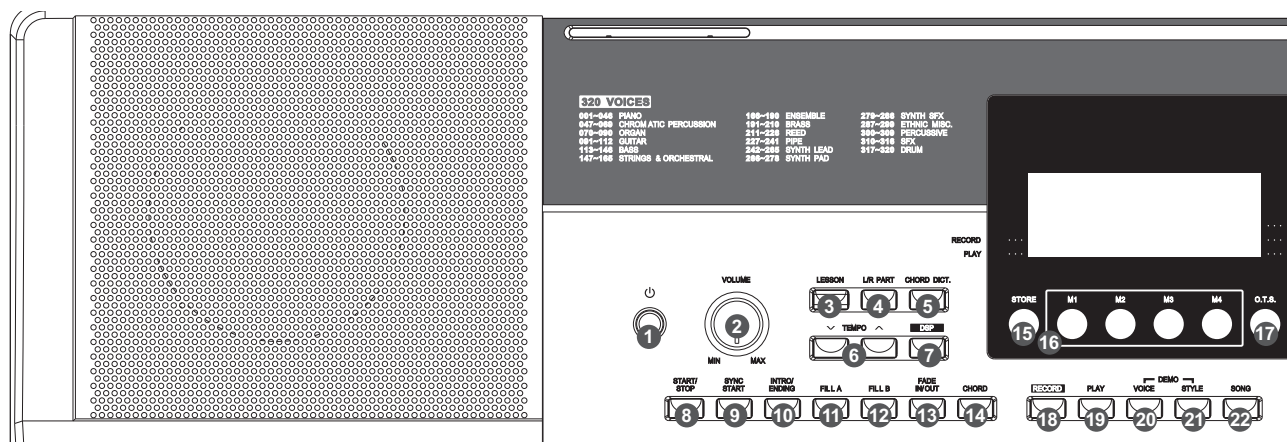

- 1. POWER ON/OFF**
Turn the power on or off.
- 2. MASTER VOLUME**
Adjust the master volume.
- 3. LESSON**
Change the Lesson Mode.
- 4. L/R PART**
Change the left and right hand in Lesson Mode.
- 5. CHORD DICT.**
Enter the Chord Dictionary.
- 6. TEMPO + / -**
Change the current tempo.
- 7. DSP**
Turn the DSP effect on and off.
- 8. START/STOP**
Start or stop playing the song in Song Mode.
Start or stop playing the style in Style Mode.
- 9. SYNC START**
Turn the SYNC START on or off.
- 10. INTRO / ENDING**
Select Intro or Ending of style.
- 11. FILL A/MAIN A**
Play the Fill-in, and change to MAIN A.
- 12. FILL B/MAIN B**
Play the Fill-in and change to MAIN B.
- 13. FADE IN/OUT**
Turn the Fade In or Fade Out on.
- 14. CHORD**
Changes the chord detect mode.
- 15. STORE**
Register the memory.
- 16. M1-M4**
Recall the memory settings.
- 17. O.T.S.**
Enter the One Touch Setting Mode.
- 18. RECORD**
Start or stop real-time recording.
- 19. PLAY**
Play back the recorded user song.
- 20. VOICE**
Enter the Voice Mode.
- 21. STYLE**
Enter the Style Mode.
- DEMO**
Press VOICE and STYLE buttons simultaneously will start the DEMO playback.
- 22. SONG**
Enter the Song Mode.
- 31. PITCH BEND**
Bend notes up or down.

Rear Panel

- 32. USB**
Connect to a computer.
- 33. SUSTAIN**
Connect a sustain pedal.
- 34. PHONE**
Connect a pair of headphones.
- 35. DC IN**
Connect DC IN power adaptor (optional).

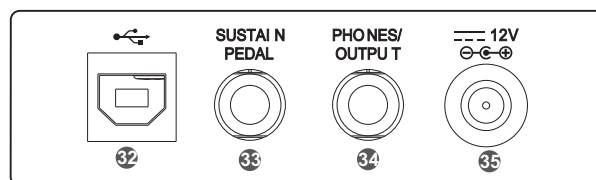

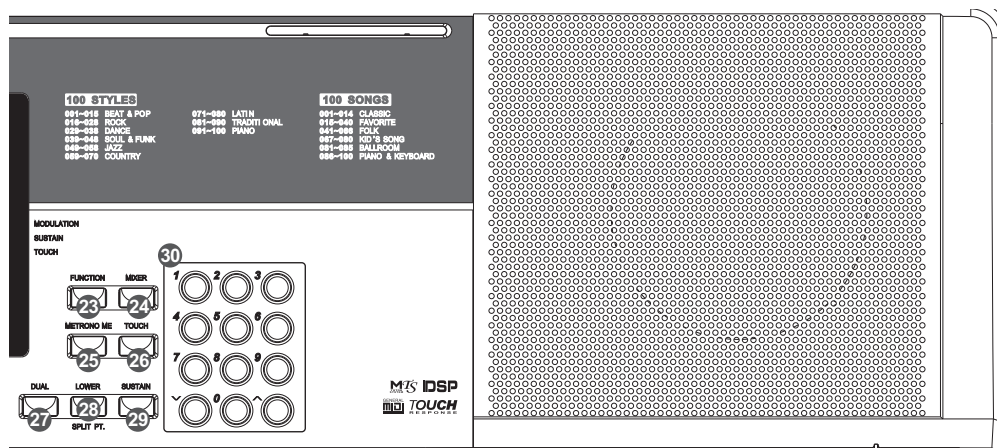

23. FUNCTION

Enter the Function Mode.

24. MIXER

Enter the Mixer Mode.

25. METRONOME

Turn the metronome on and off.

26. TOUCH

Turn the Touch response on and off.

27. DUAL

Turn the DUAL layer on or off.

28. LOWER

Turn the LOWER layer on or off.

29. SUSTAIN

Turn the Sustain effect on or off.

30. +, -, NUMBER KEYS

Select the number or set parameters value.

Display

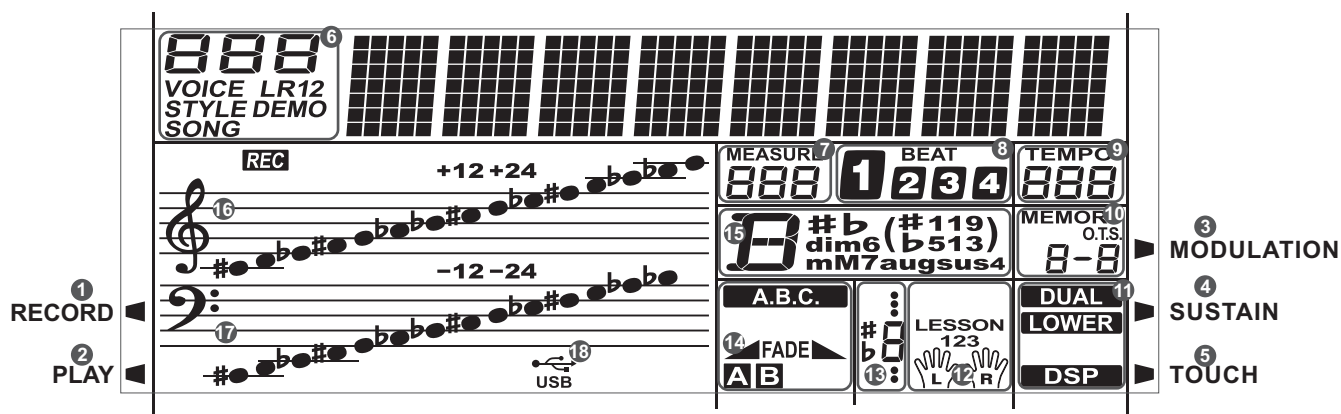

1. RECORD

2. PLAY

3. MODULATION

4. SUSTAIN

5. TOUCH

6. VOICE/STYLE/DEMO/SONG

7. MEASURE

8. BEAT

9. TEMPO

10. STROE M1-M4/ONE TOUCH SETTING

11. DUAL/DSP

12. LEFT/RIGHT HAND LESSON MODE

13. SCORE

14. A.B.C./FADE/A/B

15. CHORD

16. TREBLE CLEF

17. BASS CLEF

18. USB

Setup

This section contains information about setting up your instrument and preparing to play. Please go through this section carefully before turning the power on.

Power Supply

You can power the unit either by batteries or by power adaptor. Follow the instructions described below.

Using Batteries

6 pieces of AA size (SUM-3 or Lr6) or equivalent alkaline batteries must first be installed into the battery compartment.

1. Open the battery compartment cover located on the bottom cabin of the unit.
2. Insert the batteries, carefully follow the polarity markings on the cabinet.
3. Replace the compartment cover, making sure that it locks firmly in place.

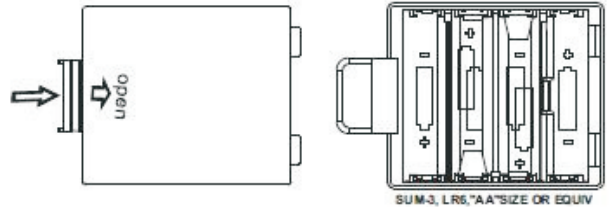

Caution:

Do not mix old and new batteries.
Always use same types of batteries.
Always remove the batteries from the unit when it is not being used for an extended period of time.

Using Power Adaptor

1. First, please make sure that POWER ON/OFF switch of the instrument is set to OFF.
2. Connect the AC adaptor to the power supply jack.
3. Plug the AC adaptor into an AC outlet. And when turning the power OFF, simply reverse the procedure please. This will automatically cut off the battery power supply.
4. Turn the power ON.

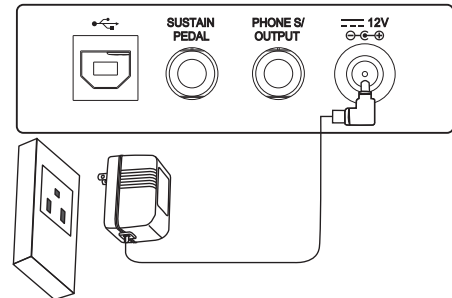

Note:

When the keyboard is not in use or in the time of thunderstorm, please disconnect the power for safety purpose.

In order to save energy, we have designed the “Automatic Shutdown” function to the keyboard. With this function, the keyboard will shutdown automatically when you have left it idle for more than 30 minutes. If you don't need this feature, just press and hold the [C2] key (the 1st key) and turn it on.

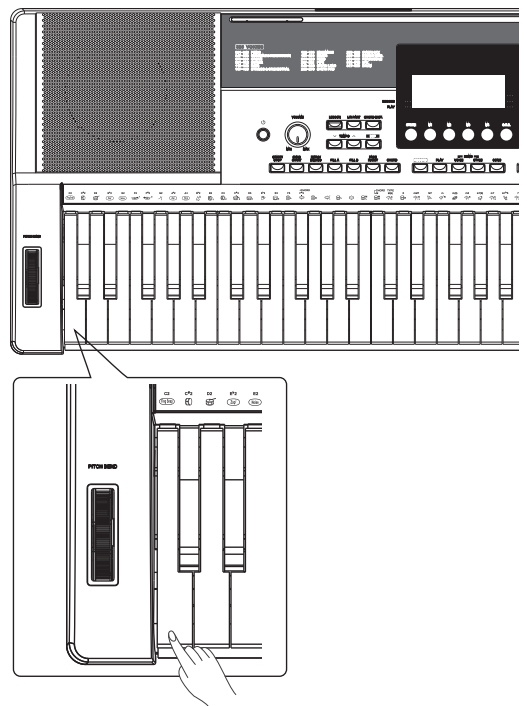

Connecting a Footswitch

An optional footswitch can be plugged into the sustain jack and be used to switch sustain on or off. Simply by pressing a sustain footswitch, you will have a natural sustain as you play.

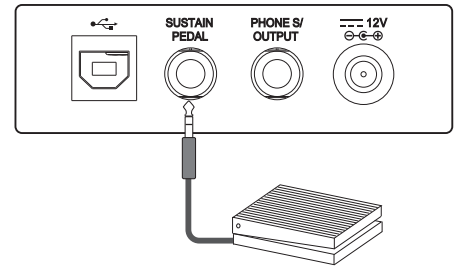

Connecting a pair of Headphones

A standard pair of stereo headphones can be connected to the PHONES jack for private practice or late-night playing. The internal stereo speaker system is automatically shut off when a pair of headphones is plugged into this jack.

Note:

Do not listen with the headphones at high volume for long periods of time. Doing so may cause hearing loss.

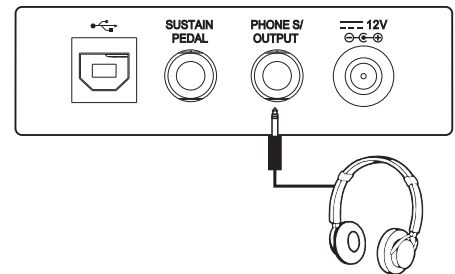

Connecting an Audio Equipment

The PHONES jack can be also connected with an audio equipment, such as an amplifier, mixer, recorder, etc.

Note:

To avoid damaging the speakers, please ensure that the volume has been set to the minimum level before connecting the power and other devices.

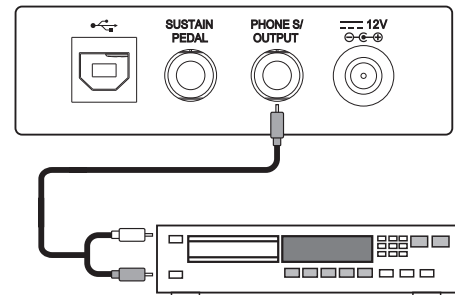

Connecting a Computer

The instrument receives and transmits MIDI messages via the USB connector.

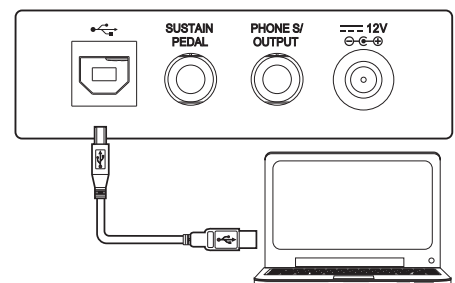

Playing the Demos

The instrument features 100 demo songs.

1. Press the [STYLE] and [VOICE] buttons simultaneously to start playing the demo.
2. Select a demo song.
Use the data dial, the number keys, the [+] button or the [-] button to select the desired demo song.
3. Adjust the volume with the [MASTER VOLUME] knob.
4. Press the [STYLE] and [VOICE] buttons simultaneously again or press the [START/STOP] button to stop playing and exit the demo mode.

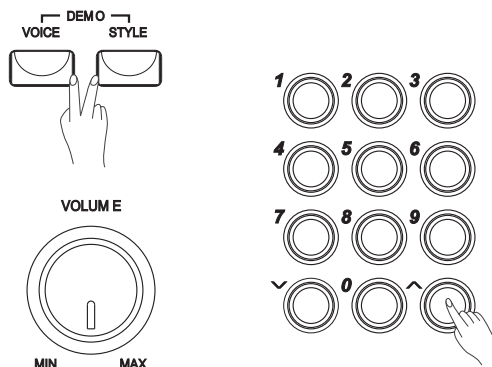

Note:

In the DEMO mode, all buttons except START/STOP, TEMPO+, TEMPO-, +, -, DSP, VOLUME, POWER ON/OFF will not be available.

Playing Voices

The keyboard has 320 remarkably realistic built-in voices, including Piano, Woodwind, Saxophone, Drum Kits and many more. Please refer to **Voice List**.

Selecting a Voice

1. Press the [VOICE] button.
Enter the VOICE mode. LCD shows “VOICE R1”, the voice number and the voice name.
2. Select a voice.
Use the data dial, the number keys, the [+] button or the [-] button to select the voice you want to play.
3. Play the voice.
You can play the keyboard and listen to the selected voice.

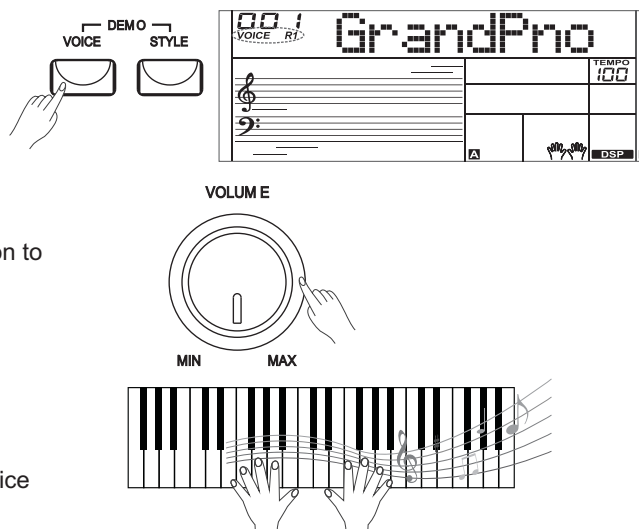

Note:

While changing a voice, pay attention to the rules. If you press the VOICE button, the voice will be changed between Voice R1 and Voice R2 when the dual voice is on.

Playing Two Voice Simultaneously-DUAL

1. Press the [DUAL] button.

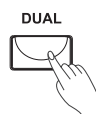

2. Play the voices.

Two different voices are sounded simultaneously in a layer.
The number of the dual voice will be displayed on the LCD.

3. Selecting a voice for VOICE R2.

When the number of the dual voice is displayed, you can select a voice for Voice R2. Use the data dial, the number keys, the [+] button or the [-] button.

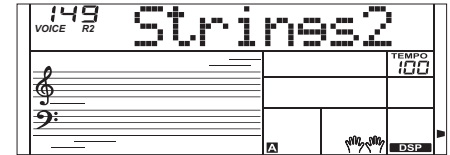

Lower

Split the Keyboard into Right and Left Areas-LOWER
The default split point is #F3.

1. Press [LOWER] button to turn on the LOWER VOICE, LCD lights the LOWER VOICE icon and displays "VOICE L" and its name.
When you play in real time, you can activate Split Mode simply by pressing this button.
2. Press [+]/[-] button, or numeric button to select the voice you want.
3. Press [LOWER] button again to turn off the LOWER VOICE. LCD turns its icon off.

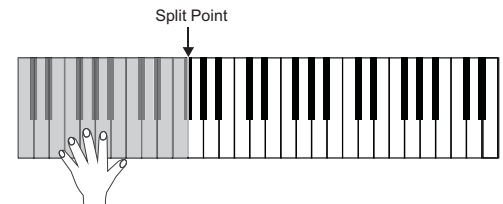
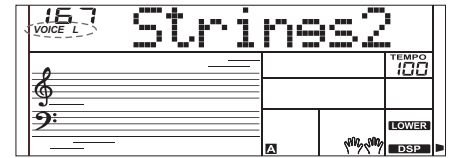

Touch

The keyboard is equipped with a touch response feature that lets you dynamically and expressively controls the level of the voice with your playing strength - just as on an acoustic instrument. Press the [TOUCH] button to adjust touch parameter: OFF, 1, 2,3. Press [+] and [-] buttons simultaneously to set its default value.

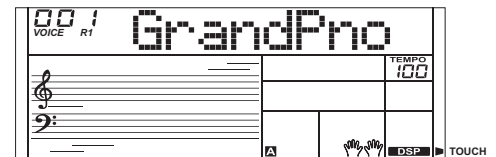

Sustain

When the Sustain feature is ON, all notes played on the keyboard would have a longer sustain. Press the [SUSTAIN] button to turn the SUSTAIN effect ON or OFF.

Note:

When you step on the "sustain pedal", the sustain effect is stronger than the effect by pressing the [SUSTAIN] button.

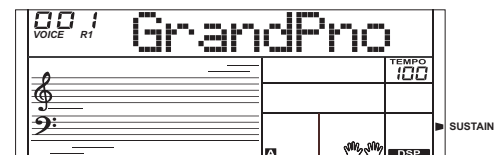

Pitch Bend Wheel

Use the pitch bend wheel to bend notes up (roll the wheel away from you) or down (roll the wheel toward you) while playing the keyboard. The pitch bend wheel is self-centering and will automatically return to normal pitch when released.

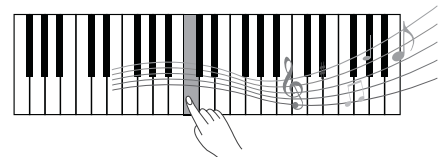

DSP Effect

This function allows you to perform the overall sound in a more realistic effect.

The DSP effect is set to ON when keyboard power on.
Press the [DSP] button to turn on or off the DSP effect.

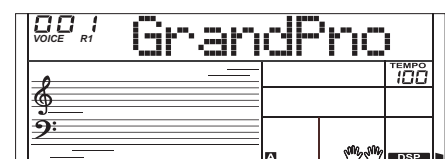

Playing the Styles

The instrument features 100 styles in a variety of different musical genres. Try selecting some of the different styles (Refer to **Style List**) and play with the auto accompaniment.

Selecting a style

1. Press the [STYLE] button.

Enter the STYLE mode. LCD shows "STYLE", the style number and the style name.

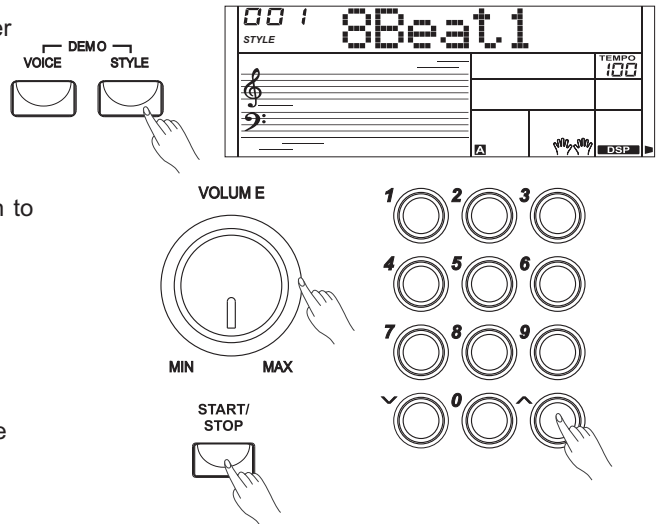

2. Use the data dial, the number keys, the [+] button, the [-] button to select the style you want to play.

3. Press the [START/STOP] button to start the rhythm tracks of the auto accompaniment.

Playing a Fill

Auto fill in function automatically adds a fill to your performance. When the fill-in is finished, accompaniment shifts to the Main section (A,B).

Note:

Hold down the FILL-IN A/B button when the style is playing, the selected FILL pattern repeats continuously until button is released. Press FILL-IN A/B when style stop, it will change to the normal section, the icon A/B on LCD will be lightened.

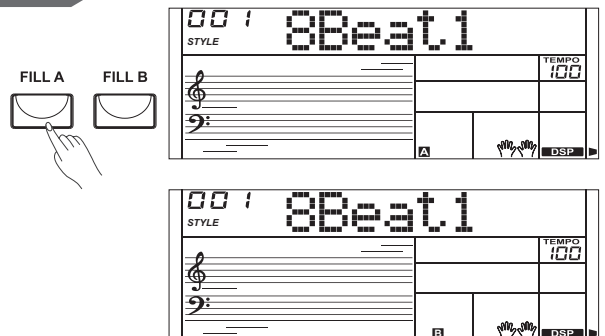

Intro/Ending

The intro is an opening section of the song. Each preset style features two different patterns. When the intro pattern finished, the system will automatically shift to the main section. Ending is used for the ending of the song. When the ending is finished, accompaniment automatically stops. The length of the ending differs depending on the selected style.

1. Press the [STYLE] button.
2. Select a style
3. Turn the Chord Mode on.
4. Turn SYNCHRONIZED START on.
5. Press the [INTRO/ENDING], the "A" or "B" flashes on LCD, the style is ready to play.
6. It will start the accompaniment as soon as you start playing in Chord section. When the playback of the intro is finished, it automatically leads into main A or B section.
7. Press the [INTRO/ENDING] again will lead it into the ending section. When the ending is finished, the auto accompaniment automatically stops.

Note:

Press [FILL A] or [FILL B] before the ending finished will lead it into main A or main B section.



Sync Start

While the style is not playing, press the [SYNC] button. The black dots below the tempo and the metronome flash, indicating the standby mode of the keyboard.

1. If the Chord Mode is OFF, pressing any key will automatically begins to play the style (rhythm track).
2. If the Chord Mode is ON, pressing any key in the left-hand range of the keyboard will automatically begins to play the style (all tracks).

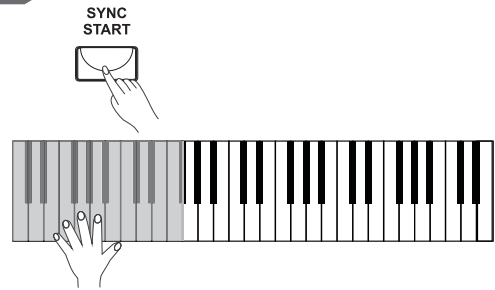

Fade In/Out

Fade In

Starting the style with fade in produces a smooth beginning, the volume increases from low to high.

Press the [FADE] button when Style is stopped, LCD will show FADE. Press the [START/STOP] button to start Style playing. LCD will show ▲FADE

The Accompaniment Volume will change from 0 to the Accompaniment Volume set value in about 8 seconds.

The keyboard volume will change from 0 to default value at the same time.

Fade Out

Stopping the style with fade out produces a smooth ending, the volume increases from high to low.

Press the [FADE] button during Style playing. LCD will show FADE▶

The Accompaniment Volume will change from the Accompaniment Volume set value to 0 in about 8 seconds, and the style stops.

The keyboard volume will change from default value to 0 at the same time.

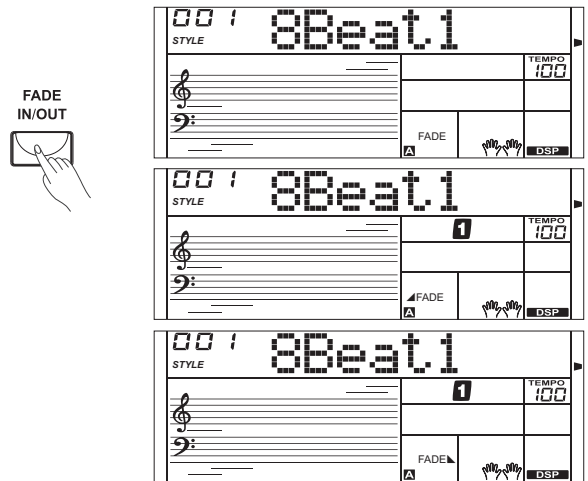

Tempo

Each style of the instrument has been programmed with a default tempo; however, this can be changed by using the [TEMPO+] or [TEMPO-] buttons.

1. Use the [TEMPO+] or [TEMPO-] button to change the tempo. The value ranges from 30 to 280.
2. Hold down the [TEMPO] buttons can change the tempo quickly. While the tempo is changing, the data dial can also change the tempo quickly.
3. Press the [TEMPO+] or [TEMPO-] buttons simultaneously to restore the default tempo setting.

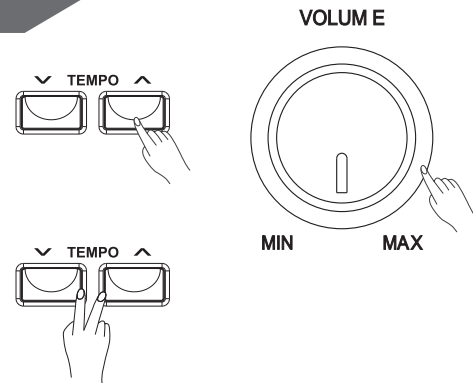

One Touch Setting

When One Touch Setting is switched on, you can instantly recall all auto accompaniment related settings including voices selection and digital effects simply with a single touch of a button.

1. Press the [O.T.S.] button to turn on the One Touch Setting for current style. LCD show O.T.S. 1.
2. Press one of the [ONE TOUCH SETTING] buttons [M1]-[M4]. Voice match the selected style can be instantly recalled with just a single button press.
3. Chord Mode is automatically turned on during O.T.S. mode.
4. Press the [O.T.S.] button again to quit One Touch Setting mode, "O.T.S." disappears.

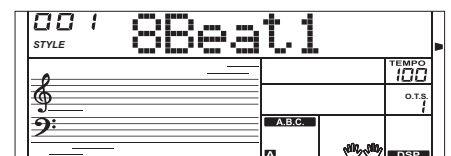
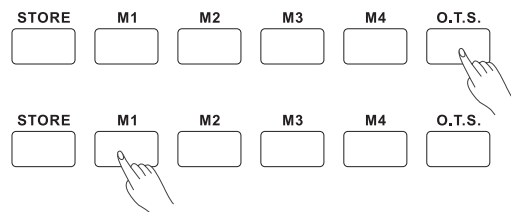

Playing the Styles

Auto Bass Chord

1. When the [CHORD] is switched on, the chords you played in the specified Chord section of the keyboard will be automatically detected and will be used to control the playback of the selected style.
2. Press the accompaniment keys, the corresponding chord will display on LCD.
3. Split Point Set
Hold down [SPLIT PT.] button will enter in Split Point Set mode, LCD show "Split Pt" and the split point key number. Press keyboard set the split point key, and release the [SPLIT PT.] button, new split point key number is saved. The split point key and the other keys on the left of it are accompaniment keys.

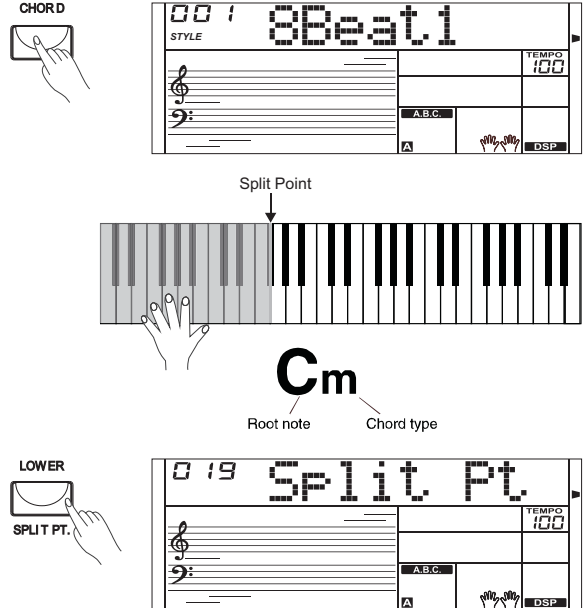

SINGLE FINGER

Single finger type not only can detect single finger but also can detect multi finger. And the single finger makes it easily to play chords through only one, two or three keys. Including major, minor, seventh, and minor seventh chord. Refer to relevant picture on the right for details.

MULTI FINGER

Multi finger type only can recognize those chords have listed in the chord list, and also can be found in the dictionary function.

C		★ Major Triad Only press the root note on the keyboard.
Cm		★ Minor Triad Press the root note and the nearest left black key simultaneously.
C7		★ Seventh chord Press the root note and the nearest left white key simultaneously.
Cm7		★ Minor seventh chord Press the root note and the nearest left white and black keys simultaneously.

0 C 	1 C ₆ 	2 CM ₇ 	3 CM ₇ (#11) 	4 CM(9) 	5 CM ₇ (9)
6 C ₆ (9) 	7 C _{aug} 	8 Cm 	9 Cm ₆ 	10 Cm ₇ 	11 Cm ₇ (b5)
12 Cm(9) 	13 Cm ₇ (9) 	14 Cm ₇ (11) 	15 CmM ₇ 	16 CmM ₇ (9) 	17 Cdim
18 Cdim ₇ 	19 C ₇ 	20 C ₇ sus ₄ 	21 C ₇ (b5) 	22 C ₇ (9) 	23 C ₇ (#11)
24 C ₇ (13) 	25 C ₇ (b9) 	26 C ₇ (b13) 	27 C ₇ (#9) 	28 CM ₇ aug 	29 C ₇ aug
30 C _{sus} ₄ 	31 C ₁₊₂₊₅ 	Notes enclosed in parenthesesⓂare optional; the chords could be recognized without them.			

Function Menu

Press [FUNCTION] button to enter the menu of functions. The default option of the menu is "Transpose". When you enter the menu next time, you will find the option is the same as last time. Press [FUNCTION] button repeatedly, select the option to be set. Use [+]/[-] button to set the parameter.

The option and the parameters are as the follows:

Content	LCD Display	Range
Transpose	XXX Transpose	-12~+12
Octave	XXX Octave	-1~+1
Modulation	Modul	ON/OFF
Beat	XX Beat	0, 2...9
Tune	XXX Tune	-50...50
MIDI Receive	XXX Midi in In	01-16, ALL
MIDI Transmit	XXX Midi out	Out 01—16
Automatic Shutdown	XXX PowerOff	30, 60, OFF

Note:

If you don't press any button for 3 seconds after entering FUNCTION menu, it will quit automatically.

TRANSPOSE

Press the [FUNCTION] button to set the transpose. The LCD displays the current transpose value "xxx Transpos". Use [+]/[-] button to select the transpose value. This function can set from -12 to +12. Press [+] and [-] buttons simultaneously to set its default value "0".

OCTAVE

Press the [FUNCTION] button to set the octave. The LCD displays the current octave value "xxx Octave". Use [+]/[-] button to select the octave value. This function can change the keyboard from -1 to +1 octaves.

Press [+] and [-] buttons simultaneously to set its default value.

MODULATION

Press the [FUNCTION] button to set the modulation. The LCD currently display "Modul". Use [+]/[-] button to set modulation ON/ OFF.

Note: This modulation effect is unavailable to percussion.

BEAT

Press the [FUNCTION] button to set the beat function, LCD displays "xxx Beat". Press the [+] or [-] button to change the beat value: 0 2 3 4 5 6 7 8 9. The default value is 4.

FUNCTION

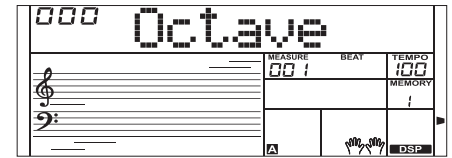

FUNCTION

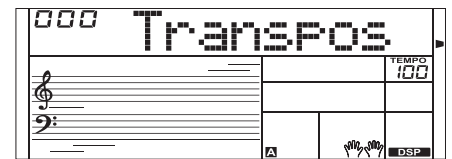

FUNCTION

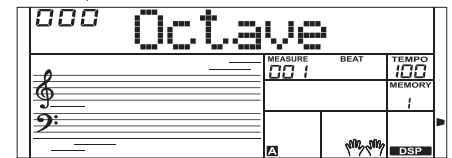

FUNCTION

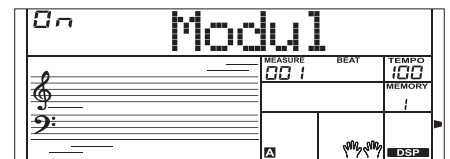

FUNCTION



Other Function

TUNE

Press the [FUNCTION] button to select the Tune settings. The LCD displays the tune value as "xxx Tune". Use [+] / [-] to change the tune value. Its range is from -50 to +50 cents only by the right area of keyboard. Press [+] and [-] buttons together will set the TUNE to its default value.

Note:

The tune setting will be applied to both keyboard and style.

FUNCTION

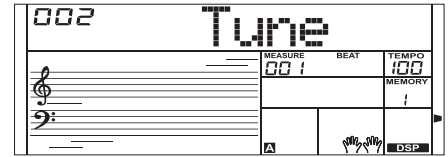

MIDI SETTING

Press the [FUNCTION] button to select the MIDI IN/OUT settings. The LCD displays the name as "xxx Midi In" and "xxx Midi Out". You can set the channel of MIDI OUT by TRANSMIT. The default setting is "001", channel 2~16 can also be selected. Use [+] / [-] button to select the channel.

You can set the channel of MIDI IN by RECEIVE. The default setting is "all", channel 1~16 can also be selected. Use [+] / [-] button to select the channel.

FUNCTION

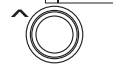
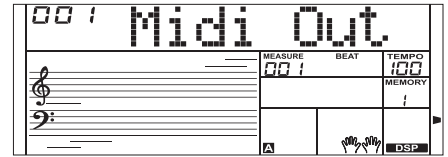

Automatic Power Off

1. Press the [FUNCTION] button repeatedly until the LCD displays "XXX Power Off".
2. The LCD displays the time value. The value ranges OFF, 30 and 60, the default value is 30. Change the time value.
3. Use [+] or [-] button to change the Power Off time value. Press [+] and [-] simultaneously to restore the default value: 30.

FUNCTION

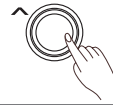
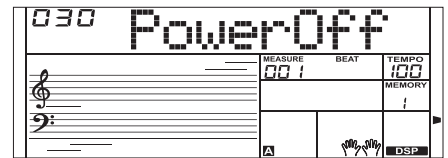

Mixer

Press [MIXER] button to enter the menu of MIXER. The default option of the menu is "Accomp", When you enter this menu next time, you will find the option is the same as last time. Press [MIXER] button, select the option you want to set. Use [+] / [-] to set the parameter.

The option and the parameters are as the follows:

Content	LCD Display	Range
Accompaniment VOLUME	XXX Accomp	0-32
Rhythm Main VOLUME	XXX Rhythm_m	0-32
Bass VOLUME	XXX Bass	0-32
Chord 1 VOLUME	XXX Chord 1	0-32
Chord 2 VOLUME	XXX Chord 2	0-32
Chord 3 VOLUME	XXX Chord 3	0-32
Voice R1 VOLUME	XXX Upper1	0-32
Voice R2 VOLUME	XXX Upper2	0-32
Voice L VOLUME	XXX Lower	0-32

Note:

If you don't press any buttons for 3 seconds after entering the MIXER menu, it will quit automatically.

Press [+] and [-] buttons simultaneously, the LCD displays "OFF", it means this parameter volume is turned off. Press [+] and [-] buttons simultaneously again, the LCD will display the last volume level.

MIXER

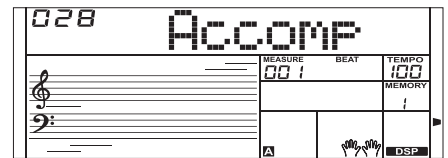
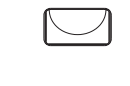

There are 4 memories (M1-M4).

1. While holding the [STORE] button, press one of the MEMORY buttons: [M1] - [M4] to register the panel settings. The new settings will replace the previous memory data. LCD show "Mem Stor". The settings include the number of voice, the number of style, tempo, beat value, sustain effect, etc.

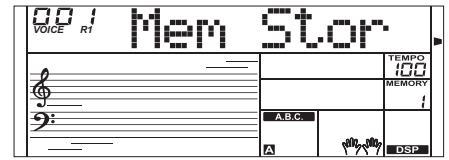

2. Press one of the MEMORY buttons: [M1] - [M4] to recall the panel settings.

Note:

The stored settings can not be recalled when the One Touch Setting function is on. The stored settings will be returned to the default settings after you turned off the power.

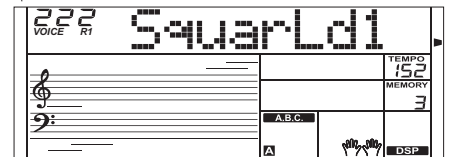
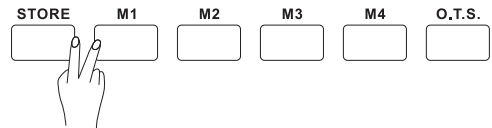

Chord Dictionary

If you know the name of a chord but don't know how to play it, you can use the Chord Dictionary function.

1. Press the [CHORD DICT.] button to enter this mode. The LCD displays the Chord Type and Chord Notes.
2. The keys on and above the C4 are used to assign the Chord Type, the keys on and above C5 are used to assign the Chord Root. When the chord Type and Chord Root are confirmed, the LCD will display the Chord and its staff position.
3. Play the chords on the keyboard according to the display. If you press the correct notes, you will hear a prompt applause sound.
4. Press the [CHORD DICT.] button again to exit this mode.

CHORD DICT.

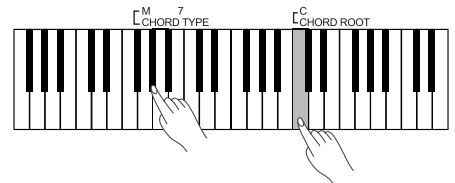
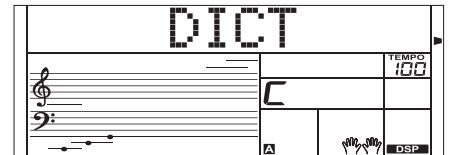

24 Chords will be displayed in the dictionary mode as follows:

Note	Chord root	Note	Chord root	Note	Chord root
C6	C	C4	M	C5	7(b9)
C#6	C#/Db	C#4	M(9)	C#5	7(9)
D6	D	D4	6	D5	7(#9)
Eb6	Eb/D#	Eb4	mM7	Eb5	7(b13)
E6	E	E4	M7	E5	7(13)
F6	F	F4	m	F5	7(#11)
F#6	F#/Gb	F#4	m(9)	F#5	dim7
G6	G	G4	m6	G5	dim
Ab6	Ab/G#	Ab4	m7(9)	Ab5	7aug
A6	A	A4	m7	A5	aug
Bb6	Bb/A#	Bb4	m7b5	Bb5	7sus4
B6	B	B4	7	B5	sus4

Playing the Songs

The instrument features 100 songs (Refer to **Song List**). Each song can be practiced in LESSON mode.

Listening to the Songs

1. Press the [SONG] button to enter the song mode. It will play all songs circularly. Press the [SONG] button again, it will stop the song and exit the song mode.
2. In song mode, use the data dial, the number keys and [+] or [-] button to select a song.
3. Once you start playing a song by pressing [START/STOP] button, it will play current song repeatedly. Press the [START/STOP] button again, it will stop the current song but not exit the song mode.
4. Use the [TEMPO+] or [TEMPO-] button to change the tempo of the current song.
5. When the song is stopped, press [STYLE], [VOICE], [DUAL],[LOWER],[M1] - [M4] to exit the song mode.

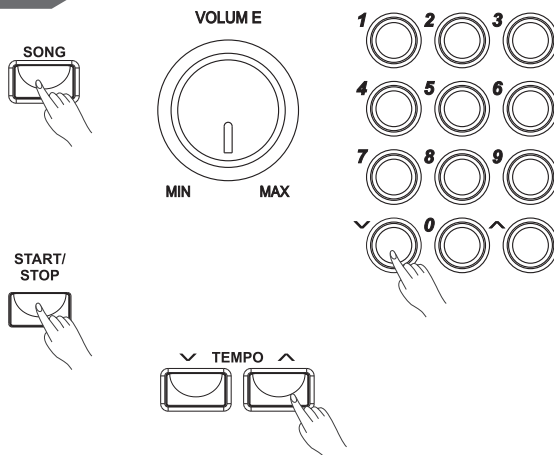

Lesson Mode

In the instrument, there are 3 different ways to practice the songs: time value training, note correction training, melody off. And the keyboard has a grading system to help you to know well about your progress.

1. In Song mode, press the [LESSON] button to enter the lesson mode or switch the lesson mode.
2. Press the [START/STOP] button to start learning. The LCD will display the note need to be played.
3. Press the [START/STOP] button again to stop learning.
4. There are 3 lesson modes and a grading system.
 - Lesson 1:** the keyboard only grade the time value of the playing, don't care the correction of the note.
 - Lesson 2:** the keyboard only grades your practice by the note; doesn't care about the correctness of the timing. Only when you play the correct note, the song will continue to the next note.
 - Lesson 3:** the keyboard will score your practice by the correction of the time value and note.**Grade:** In lesson mode, when you finished learning the current the song, the keyboard will play the prompt sound to tell you the level you get.
 - Level 1:** Ok
 - Level 2:** Good
 - Level 3:** Very Good
 - Level 4:** Excellent

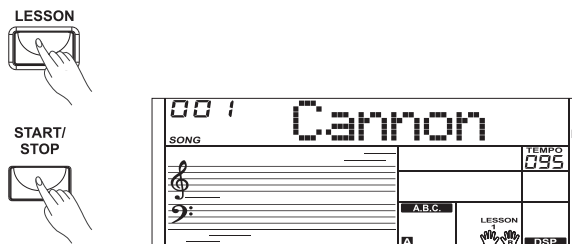

After grading, the song will be playing again, you can learn it again.

Recording and Playback

You can record your performance (up to 350 notes), and the accompaniment.

1. Press the [RECORD] button, the record flag appears on the left of LCD, the beat flashes.
2. Play the notes you want to record or press the [START/STOP] button to start recording. If you want to record your performance accompanied with the style, please turn on the chord mode, and play the chords on the left of the keyboard.
3. Press the [RECORD] button again to stop recording. The record flag disappears.
4. Press the [PLAY] button to play the notes you recorded. The play flag appears on the left of LCD.
5. Press the [PLAY] button again to stop it. The play flag disappears.
6. When recording, press [PLAY] button can stop recording and play the notes you recorded.

Note:

If you turned off the keyboard, the data you have recorded will be lost.

RECORD



START/
STOP

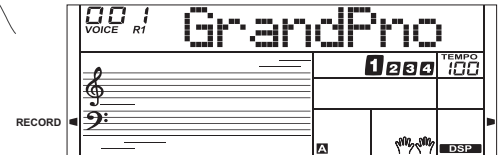

PLAY

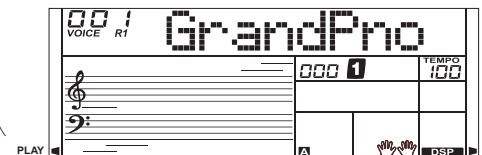

MIDI Functions

By using the MIDI functions you can expand your musical possibilities. This section explains what MIDI is, and what it can do, as well as how you can use MIDI on your instrument.

What's MIDI?

MIDI (short for Musical Instrument Digital Interface) allows a wide variety of electronic musical instruments, computers and other related devices to connect and communicate with one another. MIDI carries event messages that specify notation, pitch and velocity, control signals for parameters such as volume, vibrato, audio panning, and program change information to change the voice selections.

The instrument can output the real-time playback information via MIDI and control external MIDI devices. The instrument can also accept incoming MIDI messages and generate sound accordingly.

MIDI Terminals

MIDI Connection

The electronic keyboard is equipped with a standard USB interface instead of conventional MIDI IN and MIDI out connectors. The USB interface allows the keyboard to be connected to a computer without the need to separately purchase a MIDI interface for the computer. Most computers will automatically recognize the keyboard as a MIDI interface, allowing MIDI messages to be received from, or sent to, music programs running on the computer. To connect the keyboard to a computer you will need a standard USB A-B cable and suitable software such as a music sequencing program.

Note:

Activate the computer from a sleep/suspended/standby mode before connecting the USB cable.
Connect the USB cable to the instrument and a computer before turning the power of the instrument on.

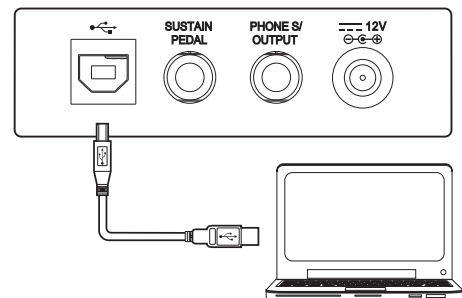

Problem	Possible Cause and Solution
The speakers produce a “pop” sound whenever the power is turned ON or OFF.	This is normal and is no cause for alarm.
No sound results when the keyboard is played.	Make sure the master volume is set at appropriate levels.
When using a mobile phone, noise is produced.	Using a mobile phone in close proximity to the instrument may produce interference. To prevent this, turn off the mobile phone or use it further away from the instrument.
The auto accompaniment does not play back even Sync is in standby condition and a key is pressed.	You may be trying to start accompaniment by playing a key in the right-hand range of the keyboard. To start the accompaniment with Sync Start, make sure to play a key in the left-hand range of the keyboard.

Specifications

Keyboard

61

Display

Multi-functional LCD

Polyphony

32

Voice

320, including 4 drum kits

Style

100

Song

100

Demo

100

Tempo

30-280

Registration Memory

4

Control button

Power on/off switch, Function, Mixer, Tempo +/-, ChordDict, Lesson, L/R Part, DSP, Style, Voice, Song, Memory, M1-M4, O.T.S., Dual, Sustain, Touch, Metro, Lower

Accompaniment Control

Start/Stop, Sync Start, Intro/Ending, Fill A, Fill B, Fade In/Out, Chord

Record Function

Record, Play

Connectors

DC IN, Phones, USB, Sustain

Power Supply

DC IN 12V

Speaker

4Ω 5W + 5W

Dimensions

955(W) X 360(D) X 145(H)mm

Weight

5.5Kg(without batteries)

* All specifications and appearances are subject to change without notice.

Voice List

No	Name	LCD Name
PIANO		
1	Acoustic Grand Piano 1	GrandPn1
2	Acoustic Grand Piano 2	GrandPn2
3	Acoustic Grand Piano (dark)	GrandPnD
4	Octave Grand Piano 1	OctPno1
5	Octave Grand Piano 2	OctPno2
6	Octave Grand Piano 3	OctPno3
7	Piano & Choir	Pno&Cho
8	Acoustic Grand Piano (wide)	GrandPnW
9	Bright Acoustic Piano 1	BritPno1
10	Bright Acoustic Piano 2	BritPno2
11	Bright Acoustic Piano 3	BritPno3
12	Bright Acoustic Piano 4	BritPno4
13	Bright Acoustic Piano 5	BritPno5
14	Bright Piano (stereo) 1	BritPnS1
15	Bright Piano (stereo) 2	BritPnS2
16	Detuned Electric Piano 1	DetunEP1
17	Detuned Electric Piano 2	DetunEP2
18	Chorus Piano	ChoruPno
19	Bright Acoustic Piano (wide)	1BritPnW1
20	Bright Acoustic Piano (wide)	2BritPnW2
21	Piano & Vibraphone	Pno&Vib
22	Electric Grand Piano	E.Grand
23	Electric Grand Piano (wide)	E.GrandW
24	Honky-tonk Piano	HnkyTonk
25	Honky Tonk Piano (dark)	HnkTonkD
26	Honky Tonk Piano (wide) 1	HnkyTkW1
27	Honky Tonk Piano (wide) 2	HnkyTkW2
28	Electric Piano 1	E.Piano1
29	Electric Piano (stereo)	E.PianoS
30	50's Electric Piano	50'sEP
31	Electric Piano (wide) 1	EPianoW1
32	Electric Piano (wide) 2	EPianoW2
33	Electric Piano (wide) 3	EPianoW3
34	Electric Piano (wide) 4	EPianoW4
35	Electric Piano 2	E.Piano2
36	Detuned Electric Piano 1	DetunEP1
37	Detuned Electric Piano 2	DetunEP2
38	Harpsichord	Harpsi
39	Harpsichord (wide)	HarpsiW
40	Harpsichord (octave mix) 1	HarpsiO1
41	Harpsichord (octave mix) 2	HarpsiO2
42	Harpsichord (with key off)	HarpsiOf
43	Clavi	Clavi
44	Clavi (stereo)	ClaviS
45	Clavi (wide)	ClaviW
46	Wah Clavi	WahClavi
CHROMATIC PERCUSSION		
47	Celesta	Celesta
48	Celesta (dark)	CelestaD
49	Celesta & Sine	Cele&Sin
50	Reecho Bell	ReBell
51	Celesta & Music Box	Cel&Mbox
52	Glockenspiel	Glocken
53	Glockenspiel & Sine	Glkn&Sin
54	Music Box	MusicBox
55	Vibraphone	Vibra
56	Vibraphone (wide)	VibraW
57	Vibraphone & Bell	Vibr&Bel

58	Vibraphone & Harpsichord	Vibr&Hrp
59	Marimba	Marimba
60	Marimba (wide)	MarimbaW
61	Sine Marimba	SinMarmb
62	Marimba (stereo)	MarimbaS
63	Marimba & Vibraphone	Marm&Vib
64	Wood Drum	WoodDrum
65	Xylophone	Xylophon
66	Tubular Bells 1	TubuBel1
67	Tubular Bells 2	TubuBel2
68	Tubular Bells 3	TubuBel3
69	Dulcimer	Dulcimer
ORGAN		
70	Drawbar Organ	DrawOrgn
71	Drawbar Organ (stereo)	DrawOrgS
72	Soft Stereo Drawbar Organ	DrawOgSf
73	Mellow Drawbar Organ	MellDOrg
74	Bright Drawbar Organ	DrawOrgB
75	Percussive Organ	PercOrgn
76	Detuned Percussive Organ	DePerOrg
77	Rock Organ	RockOrgn
78	Church Organ	ChurOrgn
79	Detuned Church Organ	DeChuOrg
80	Church Organ (octave mix) 1	ChrOrgO1
81	Church Organ (octave mix) 2	ChrOrgO2
82	Reed Organ	ReedOrgn
83	Reed Organ (stereo)	ReedOrgS
84	Accordion 1	Acordin1
85	Accordion 2	Acordin2
86	Accordion (stereo)	AcordinS
87	Harmonica	Harmonica
88	Harmonica (dark)	HarmonicD
89	Tango Accordion	TangoAcD
90	Tango Accordion (dark)	TangAcD
GUITAR		
91	Acoustic Guitar (nylon) 1	NyInGtr1
92	Acoustic Guitar (nylon) 2	NyInGtr2
93	Chorus Nylon Guitar 1	NyInGtC1
94	Chorus Nylon Guitar 2	NyInGtC2
95	Nylon Guitar (stereo) 1	NyInGtS1
96	Nylon Guitar (stereo) 2	NyInGtS2
97	Acoustic Guitar (steel) 1	SteelGt1
98	Acoustic Guitar (steel) 2	SteelGt2
99	12-Strings Guitar	12StrGtr
100	Detuned Steel Guitar	DetStlGt
101	Electric Guitar (jazz) 1	JazzGtr1
102	Electric Guitar (jazz) 2	JazzGtr2
103	Electric Guitar (clean)	CleanGtr
104	Clean Guitar (stereo)	CleanGtS
105	Soft Clean Guitar	ClnGtSof
106	Chord Clean Guitar	ClnGtCho
107	Electric Guitar (muted)	MutedGtr
108	Stereo Muted Guitar	MutedGtS
109	Chord Muted Guitar	MutGtCho
110	Overdriven Guitar	Ovrdrive
111	Distortion Guitar	DistGtr
112	Guitar Harmonics	GtrHarmo
BASS		
113	Acoustic Bass 1	AcoBass1
114	Acoustic Bass 2	AcoBass2

115	Acoustic Bass 3	AcoBass3
116	Acoustic Bass 4	AcoBass4
117	Acoustic Bass Detuned	DetAcoBs
118	Velocity Crossfade Bass	VelCroBs
119	Jazz Style	JazzSty
120	Acoustic Bass & Mute Guitar	ABs&MTGT
121	Electric Bass (finger) 1	FngrBs1
122	Electric Bass (finger) 2	FngrBs2
123	Electric Bass (finger) 3	FngrBs3
124	Electric Bass (finger) 4	FngrBs4
125	Finger Bass (dark) 1	FngrBsD1
126	Finger Bass (dark) 2	FngrBsD2
127	Detuned Finger Bass 1	DeFngBs1
128	Detuned Finger Bass 2	DeFngBs2
129	Velocity Bass	VelBass
130	Bass & Distortion Guitar	Bs&DisGt
131	Electric Bass (pick) 1	PickBs1
132	Electric Bass (pick) 2	PickBs2
133	Mute Pick Bass	PickBsM
134	Pick & Finger Bass	Pk&FgBs
135	Pick Bass & Clean Guitar	PBs&ClGt
136	Detuned Pick Bass	DetPKBs
137	Fretless Bass 1	Fretles1
138	Fretless Bass 2	Fretles2
139	Slap Bass 1	SlapBas1
140	Slap Bass 2	SlapBas2
141	Slap Bass 3	SlapBas3
142	Slap Bass 4	SlapBas4
143	Synth Bass 1	SynBass1
144	Synth Bass 2	SynBass2
145	Synth Bass 3	SynBass3
146	Synth Bass 4	SynBass4
STRINGS & ORCHESTRAL INSTRUMENTS		
147	Violin 1	Violin1
148	Violin 2	Violin2
149	Two Violin	TwoVioln
150	Viola 1	Viola1
151	Viola 2	Viola2
152	Two Viola	TwoViola
153	Cello 1	Cello1
154	Cello 2	Cello2
155	Contrabass 1	Contrbs1
156	Contrabass 2	Contrbs2
157	Tremolo Strings 1	TremStr1
158	Tremolo Strings 2	TremStr2
159	Pizzicato Strings 1	PizzStr1
160	Pizzicato Strings 2	PizzStr2
161	Orchestral Harp 1	Harp1
162	Orchestral Harp 2	Harp2
163	Orchestral Harp (stereo)	HarpS
164	Timpani 1	Timpani1
165	Timpani 2	Timpani2
ENSEMBLE		
166	Strings Ensemble 1	Strings1
167	Strings Ensemble 2	Strings2
168	Strings Ensemble 3	Strings3
169	Strings Ensemble 4	Strings4
170	Stereo Strings 1	StringS1
171	Stereo Strings 2	StringS2
172	Synth Strings 1	SynStrs1

Voice List

173	Synth Strings 2	SynStrs2
174	Synth Strings 3	SynStrs3
175	Synth Strings (stereo) 1	SynStrS1
176	Synth Strings (stereo) 2	SynStrS2
177	Choir Aahs	ChoirAah
178	Choir Aahs (dark)	ChoAahD
179	Stereo Aahs 1	ChoAhS1
180	Stereo Aahs 2	ChoAhS2
181	Mellow Choir Aahs	ChoAhMel
182	Aahs & Synth Strings	Ah&SyStr
183	Big Aahs	BigAahs
184	Voice Oohs	VoiceOoh
185	Synth Voice 1	SynVoic1
186	Synth Voice 2	SynVoic2
187	Synth Voice (stereo)	SynVoicS
188	Orchestra Hit	OrchHit
189	Orchestra Hit (stereo)	OrchHitS
190	Octave Orchestra Hit	HitOctO
BRASS		
191	Trumpet 1	Trumpet1
192	Trumpet 2	Trumpet2
193	Trumpet (dark)	TrumpetD
194	Wah Trumpet	TrumpetW
195	Trombone 1	Trmbone1
196	Trombone 2	Trmbone2
197	Tuba 1	Tuba1
198	Tuba 2	Tuba2
199	Muted Trumpet 1	MuteTrp1
200	Muted Trumpet 2	MuteTrp2
201	French Horn 1	FrHorn1
202	French Horn 2	FrHorn2
203	Fifth Horn Orchestra	5thHorn
204	Brass Section	Brass
205	Synth Brass 1	SynBras1
206	Synth Brass 2	SynBras2
207	Synth Brass 3	SynBras3
208	Synth Brass 4	SynBras4
209	Synth Brass 5	SynBras5
210	Octave Synth Brass	SynBrasO
REED		
211	Soprano Sax 1	SprnSax1
212	Soprano Sax 2	SprnSax2
213	Alto Sax 1	AltoSax1
214	Alto Sax 2	AltoSax2
215	Tenor sax 1	TenoSax1
216	Tenor sax 2	TenoSax2
217	Baritone Sax 1	BariSax1
218	Baritone Sax 2	BariSax2
219	Oboe	Oboe
220	Sweet Oboe	SwetOboe
221	English Horn 1	EngHorn1
222	English Horn 2	EngHorn2

223	Bassoon 1	Bassoon1
224	Bassoon 2	Bassoon2
225	Clarinet 1	Clarinet1
226	Clarinet 2	Clarinet2
PIPE		
227	Piccolo	Piccolo
228	Flute 1	Flute1
229	Flute 2	Flute2
230	Recorder 1	Recordr1
231	Recorder 2	Recordr2
232	Pan Flute 1	PanFlut1
233	Pan Flute 2	PanFlut2
234	Blown Bottle 1	Bottle1
235	Blown Bottle 2	Bottle2
236	Shakuhachi 1	Shakchi1
237	Shakuhachi 2	Shakchi2
238	Whistle 1	Whistle1
239	Whistle 2	Whistle2
240	Ocarina 1	Ocarina1
241	Ocarina 2	Ocarina2
SYNTH LEAD		
242	Lead 1 (square) 1	SquarLd1
243	Lead 1 (square) 2	SquarLd2
244	Lead 1 (square) 3	SquarLd3
245	Lead 1b (sine)	SineLead
246	Slow Square Lead	SawLead
247	Thick Square	ThickSq
248	Quint	Quint
249	Sine Solo	SineSolo
250	Lead 2 (sawtooth) 1	SawLead1
251	Lead 2 (sawtooth) 2	SawLead2
252	Stereo Sawtooth 1	SawLdS1
253	Stereo Sawtooth 2	SawLdS2
254	Fifth Sawtooth	5thSaw
255	Lead 3 (calliope) 1	CalipLd1
256	Lead 3 (calliope) 2	CalipLd2
257	Lead 4 (chiff) 1	ChiffLd1
258	Lead 4 (chiff) 2	ChiffLd2
259	Lead 5 (charang) 1	CharnLd1
260	Lead 5 (charang) 2	CharnLd2
261	Lead 6 (voice) 1	VoiceLd1
262	Lead 6 (voice) 2	VoiceLd2
263	Lead 7 (fifths)	FifthsLd
264	Lead 8 (bass + lead) 1	Bs&Lead1
265	Lead 8 (bass + lead) 2	Bs&Lead2
SYNTH PAD		
266	Pad 1 (new age) 1	NewAgPd1
267	Pad 1 (new age) 2	NewAgPd2
268	Pad 2 (warm) 1	WarmPad1
269	Pad 2 (warm) 2	WarmPad2
270	Pad 3 (polysynth) 1	PlySyPd1
271	Pad 3 (polysynth) 2	PlySyPd2

272	Pad 4 (choir) 1	ChorPad1
273	Pad 4 (choir) 2	ChorPad2
274	Pad 5 (bowed) 1	BowdPad1
275	Pad 5 (bowed) 2	BowdPad2
276	Pad 6 (metallic)	MetalPad
277	Pad 7 (halo)	HaloPad
278	Pad 8 (sweep)	SweepPad
SYNTH SFX		
279	FX 1 (rain)	FXRain
280	FX 2 (soundtrack)	Soundtrk
281	FX 3 (crystal)	Crystal
282	FX 4 (atmosphere)	Atmosphr
283	FX 5 (brightness)	Bright
284	FX 6 (goblins)	Goblins
285	FX 7 (echoes)	Echoes
286	FX 8 (sci-fi)	Sci-Fi
ETHNIC MISC.		
287	Sitar	Sitar
288	Detuned Sitar	DetSitar
289	Banjo 1	Banjo1
290	Banjo 2	Banjo2
291	Shamisen 1	Shamism1
292	Shamisen 2	Shamism2
293	Koto 1	Koto1
294	Koto 2	Koto2
295	Kalimba 1	Kalimba1
296	Kalimba 2	Kalimba2
297	Bagpipe	Bagpipe
298	Fiddle	Fiddle
299	Shanai	Shanai
PERCUSSIVE		
300	Tinkle Bell	TnklBell
301	Agogo	Agogo
302	Steel Drums	StelDrum
303	Bass Drum	BassDrum
304	Wood Block	WoodBlok
305	Snare	Snare
306	Taiko Drum	TaikoDum
307	Melodic Tom	MelodTom
308	Synth Drum	SynDrum
309	Reverse Cymbal	RevCymb1
SFX		
310	Synth 1	Synth1
311	Synth 2	Synth2
312	Synth 3	Synth3
313	Synth 4	Synth4
314	Synth 5	Synth5
315	Synth 6	Synth6
316	Synth 7	Synth7
DRUM		
317	Standard Set	StandSet
318	Rock Set	RockSet
319	Electronic Set 1	ElecSet1
320	Electronic Set 2	ElecSet2

Style List

No	Name	LCD Name
BEAT & POP 1		
1	8 Beat 1	8Beat1
2	8 Beat 2	8Beat2
3	8 Beat 3	8Beat3
4	8 Beat 4	8Beat4
5	60's 8 Beat	60's8Bt
6	8 Beat Ballad	8BtBld
7	8 Beat Rock	8BtRock
8	16 Beat 1	16Beat1
9	16 Beat 2	16Beat2
10	16 Beat Pop	16BtPop
11	16 Beat Shuffle	16BtShfl
12	Ballad	Ballad
13	Slow Ballad	SlowBld
14	16 Beat Ballad	16BtBld
15	Unplugged	Unplugged
ROCK 1		
16	Rock	Rock
17	Pop Rock	PopRock
18	Fast Rock	FastRock
19	Slow Rock 1	SlwRock1
20	Slow Rock 2	SlwRock2
21	Rock & Roll	RockRoll
22	Heavy Metal	H.Metal
23	Blues Boogie	B.Boogie
24	Blues	Blues
25	Shuffle	Shuffle
26	Blues Shuffle	B.Shuffle
27	Rock Shuffle	R.Shuffle
28	Charleston	Charston
DANCE 1		
29	Disco 1	Disco1
30	Disco 2	Disco2
31	Disco Funk	DiscFunk
32	Dance	Dance
33	House 1	House1
34	House 2	House2
35	Rap	Rap
36	Euro Beat	EuroBeat
37	Hip Hop	HipHop
38	Techno	Techno

SOUL & FUNK 1		
39	Funky Pop	FunkyPop
40	Jazz Funk	JazzFunk
41	Cool Funky	CoolFunk
42	Soul 1	Soul1
43	Soul 2	Soul2
44	Soul Shuffle	SoulShfl
45	Soul Blues	SoulBlue
46	R & B	R&B
47	6/8 Gospel	6/8Gospl
48	Pop Groove	PopGrove
JAZZ 1		
49	Swing	Swing
50	Cool Jazz	CoolJazz
51	Pop Swing	PopSwing
52	Swing Fox	SwingFox
53	Big Band	BigBand
54	Big Band Medium	BandMedi
56	Ragtime	Ragtime
57	Dixieland	Dixeland
58	Quick Step	QuickStp
COUNTRY 1		
59	Country 1	Country1
60	Country 2	Country2
61	Pop Country	PopCntry
62	Country Rock	CtryRock
63	Country Folk	CtryFolk
64	3/4 Country	3/4Ctry
65	Country Waltz	C.Waltz
66	Country Shuffle	CtryShfl
67	Country Boogie	C.Boogie
68	Country Blues	C.Blues
69	Country Quick Step	CtryStep
70	Bluegrass	Bluegras
LATIN 1		
71	Bossa Nova 1	Bossa1
72	Bossa Nova 2	Bossa2
73	Rhumba	Rhumba
74	Pop Rhumba	P.Rhumba
75	Cha Cha	ChaCha
76	Pop Cha Cha	P.ChaCha
77	Tango	Tango

77	Tango	Tango
78	Jazz Samba	JazSamba
79	Reggae	Reggae
80	Pop Reggae	P.Reggae
TRADITIONAL 1		
81	March 1	March1
82	March 2	March2
83	German March	G.March
84	6/8 March	6/8March
85	Polka	Polka
86	Pop Polka	PopPolka
87	Waltz	Waltz
88	Slow Waltz	SloWaltz
89	Vienna Waltz	VieWaltz
90	Musette	Musette
PIANO 1		
91	Piano 8 Beat	Pno8Beat
92	Piano Ballad	PnoBalad
93	Piano Boogie	PnoBogie
94	Piano Jazz	PnoJazz
95	Piano Swing	PnoSwing
96	Piano Jazz Waltz	P.JWaltz
97	Piano Twist	PnoTwist
98	Piano March	PnoMarch
99	Piano 6/8 March	Pno6/8Mr
100	Piano Waltz	PnoWaltz

Song List

No.	Name	LCD Name
CLASSIC		
1	Cannon	Cannon
2	Meditation	Meditati
3	Old French Song	France
4	Minuet In G	Minuet
5	Ode To Joy	OdeToJoy
6	Wiegenlied	WieGenli
7	The Surprise Symphony	Surprise
8	Swan Lake	SwanLake
9	The Four Seasons	F.Season
10	Carmen	Carmen
11	Joy To The World	JoyWorld
12	Toy Symphony	Toy
13	Humoreske	Humoresk
14	Kuckucks Walzer	Kuckucks
FAVORITE		
15	It's Been A Long, Long Time	LongAgo
16	Old Folks At Home	OldFolks
17	Oh! Susanna	Susanna
18	Jeanie With The Light Brown Hair	Jeannie
19	Bill Bailey, Won't You Please Come Home?	Billhome
20	Annie Laurie	Annielau
21	From The New World	NewWorld
22	The Yellow Rose Of Texas	RoseTexa
23	Ave Maria	AveMaria
24	My Old Kentucky Home	Kentucky
25	Turkey In The Straw	Turkey
26	Deck The Halls	DeckHall
27	Grandfather's Clock	G'sClock
28	America The Beautiful	America
29	The Sideway	Sideway
30	The Entertainer	Entertai
31	The Old Gray Mare	GrayMare
32	Aloha Oe	AlohaOe
33	Solvejg's Cradle Song	Solveig
34	Camptown Races	C.Races
35	Carry Me Back To Old Virginny	Viginia
36	The Blue Bells Of Scotland	BlueBell
37	O Sole Mio	OsoloMio
38	Jingle Bells	JingBell
39	Battle Hymn Of The Republic	Battle
40	Silent Night	SitNight
FOLK		
41	Огонец	Ogoniok
42	Aura Lea	AulaLee
43	House Of The Rising Sun	HouseSun
44	Danny Boy	DannyBoy
45	I've Been Working On The Railroad	WorkRail
46	With Games	WithGame
47	Way Home	WayHome
48	Parting	Parting
49	Yankee Doodle	YankeeD
50	Red River Valley	RedRiver

No.	Name	LCD Name
51	Auld Lang Syne	AuldLang
52	When The Saints Go Marching In	Marching
53	Twinkle Twinkle Little Star	Twinkle
54	Happy Birthday To You	Birthday
55	Little Brown Jug	BrownJug
56	Michael Row The Boat Ashore	RowBoat
57	Old King Cole	KingCole
58	Jamaica Farewell	Jamaica
59	Тройка	Troika
60	Cielito Lindo	Cielito
61	If You're Happy And You Know It	ClapHand
62	American Patrol	A.Patrol
63	When Johnny Comes Marching Home	ComeHome
64	Green Sleeves	Sleeves
65	Santa Lucia	SantaLu
66	Sweet Waltz	SweetWal
KID'S SONG		
67	Angels We Have Heard On High	Angels
68	Skip To My Lou	SkipMyLo
69	London Bridge Is Falling Down	Bridge
70	Humpty Dumpty	HumptyD
71	Home On The Range	HomeRang
72	This Old Man	OldMan
73	Star Bright	StarBri
74	Ten Little Indians	TenIndia
75	Polly Wolly Doodle	PlyWlyDo
76	Santa Claus Is Coming To Town	SantaCla
77	Sippin' Cider Through A Straw	SipinCid
78	La Cucaracha	Cucaraca
79	Home Sweet Home	SwetHome
80	Up On The House Top	HouseTop
BALLROOM		
81	Kuerchake Dance	Kulzak
82	Samba	Samba
83	Tango	Tango
84	Kazakhstan Dance	Kazakhst
85	Naughty Polka	Polka
PIANO & KEYBOARD		
86	Four Little Swans	FourSwan
87	Did You Ever See A Lassie	Lassie
88	Spring	Spring
89	Impromptu	Imprompt
90	Gavotte	Gavotte
91	Nocturne	Nocturne
92	Pizzicato Polka	Pizicato
93	Moment Musical	M.Moment
94	The Rag-Time Dance	Rag-Time
95	Love	Love
96	Valse No.6 "Petit Chien"	ValseNo6
97	Rondeau	Rondeau
98	The Chrysanthemum	Chrysanf
99	Invention A 2 Voix	Invention
100	Afternoon	Afternoo

MIDI Implementation Chart

Function		Transmitted	Recognized	Remarks
Basic Channel	Default	1ch	ALL	
	Changed	x	x	
Mode	Default	x	1	
	Messages	x	x	
	Altered	*****	x	
Note Number	Note	18—114	0—127	
	:True voice	*****	0—127	
Velocity	Note on	○ 9nH,V=1-127	○ 9nH,V=1-127	
	Note off	x (9nH,V=0)	x(9nH,V=0; 8nH,V=0-127)	
After Touch	key's	x	x	
	Ch's	x	x	
Pitch Bend		○	○	
Control Change	0	○	○	Bank Select
	1	x	○	Modulation
	5	x	x	Portamento Time
	6	x	○	Data Entry
	7	x	○	Volume
	10	x	○	Pan
	11	x	○	Expression
	64	○	○	Sustain Pedal
	65	x	x	Portamento ON/OFF
	66	x	○	Sostenuto Pedal
	67	x	○	Soft Pedal
	80	x	○	Reverb Program
	81	x	○	Chorus Program
	91	x	○	Reverb Level
	93	x	○	Chorus Level
	120	x	○	All Sound Off
	121	x	○	Reset All Controllers
123	○	○	All Notes Off	
Program Change	:true	*****	0—127	
System Exclusive		x	x	
System Common	:SongPosition	x	x	
	:Song Select	x	x	
	:Tune	x	x	
System Real Time	:Clock	x	x	
	:Commands	x	x	
Aux Messages	:LOCAL ON/OFF	x	x	
	:All Notes Off	○	○	
	:Active sense	x	○	
	:Reset	x	○	
Notes:				

- Mode 1: OMNI ON, POLY
- Mode 2: OMNI ON, MONO

- Mode 3: OMNI OFF, POLY
- Mode 4: OMNI OFF, MONO
- : YES
- x: NO